

**Lever Drum Pump
+ Garden Hose Nut**

KTLV05

Value engineered for optimal performance at an affordable cost

Built-in 1-1/2" & 2" bung for use on drums with either openings

Nitrile rubber piston rings for smooth operation

Complete with curved metal spout & telescopic PVC / Steel suction tube for use on 15-55 gallon (50-205 liter) barrels

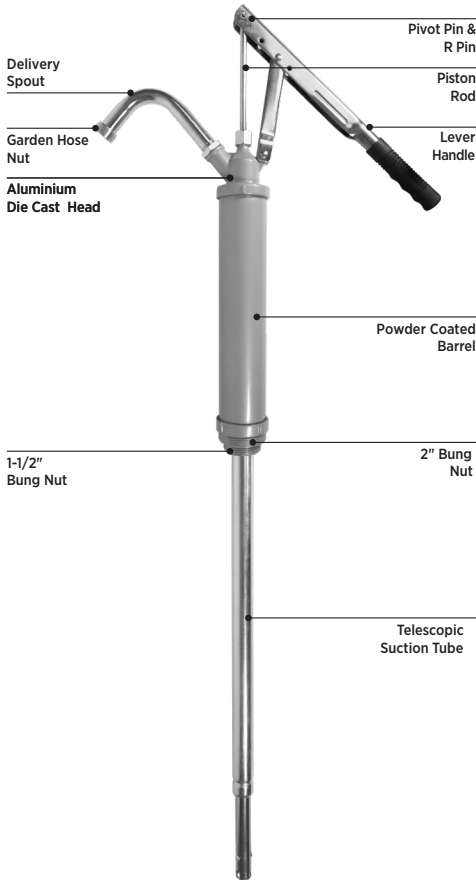

DELIVERS
UP TO
1 GAL. / 9 STROKES
(300 ML / STROKE)

SPECIFICATIONS

MODEL	KTLV05
Fits	15-55 gallon (50-205 liter) barrels
Delivery Rate	1 gallon / 9 strokes (300 ml / stroke)
Recommended Use	Motor Oil, Transmission Fluid, and Hydraulic Oils
Do Not Use	Water Based Fluids, Antifreeze, Solvents, Acids, Gasoline etc.
Wetted Components	Steel, Aluminum, & NBR
Suction Tube Material	Steel
Suction Tube Length	18" to 34-1/2" (460 to 875 mm)

SAFETY INFORMATION

- Keep the work area clean and dry. Damp or wet work areas can result in injury.
- When not in use, tools and equipment should be stored in a dry location to inhibit rust. Always lock up tools and equipment, and keep out of reach of children.
- Use the right tool for the job. Do not attempt to force small equipment to do the work of larger industrial equipment. Do not modify this equipment.
- Check for damaged parts. Before using this product, carefully check that it will operate properly and perform its intended function. Check for damaged parts and any other conditions that may affect the operation of this product. Replace damaged or worn parts immediately.

WARNING!

- Read and understand all instructions. Failure to follow all instructions listed above may result in electric shock, fire and/or serious injury.

PACKAGE CONTENT

DESCRIPTION	QUANTITY
Pump with lever handle	1
Delivery spout	1
Suction tube	1
O.I.P.M	1

BEFORE INSTALLATION

- **Eyes protection:** Wear a protective mask or protective eyewear.
- **Skin protection:** Avoid repeated and prolonged contact of oils with the skin by wearing impermeable protective gloves.
- Check that the equipment has not suffered any damage during transport or storage. Clean the inlet and outlet openings, removing any dust or residual packing material.
- Read the instructions carefully before using the pump and keep them for further reference.
- Do not smoke during refueling

INSTALLATION

Refer "Exploded View"

1. Screw the telescopic suction tube (27) into the bung nut (20). Tighten the connection securely to eliminate any air leaks.

2. Screw the bend pipe (28) onto the pump head. Tighten securely to eliminate any possibility of leakage.
3. Extend the telescopic suction tube (27) little longer than the height of the drum.
4. Screw the pump into the drum's bung (20). Tighten the pump assembly securely by grasping the pump barrels (15) and rotating.
5. Pull the plunger rod (2) of piston sub assembly up and attach the lever handle rod to the plunger rod (2) using the bolt (1).

NOTE:

1. Apply thread sealant on all threaded connections. Do not use undue force when tightening.
2. Do not tighten the pump by holding the lever handle (24).

OPERATING INSTRUCTIONS

(Refer "Exploded View")

Now the pump is ready, start operating the pump by giving quick strokes to the lever handle.

Prime the pump

If the pumps fails to operate, it may be necessary to prime.

1. Turn the delivery spout upward.
2. Pour a few drops of the fluid being dispensed into the spout.
3. Start the pump by moving the lever handle (24) with several quick strokes.
4. If the pump still fails to start, remove the pump from the drum and ensure the telescopic suction tube (27) is extended enough to reach the bottom of the drum

WARNING!

- The pump is constructed using plated steel components. It should never be used to transfer fluids that may cause the pump to rust. Certain fluids have a tendency to build a coating on the surface when dry, it is recommended to leave the lever handle in upright position when not in use

MAINTENANCE

(Refer "Exploded View")

- This pump required little maintenance, however to maximize the useful life of the pump it is recommended to inspect and, if necessary, periodically clean the suction tube (27).

EXPLODED VIEW

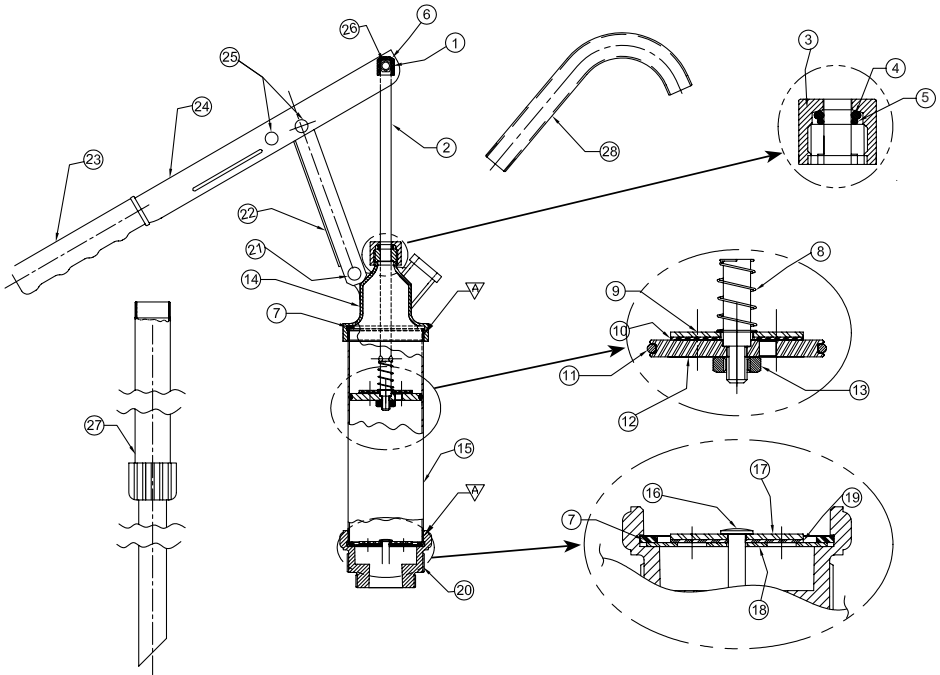

PARTS LIST

REF NO.	PARTS DESCRIPTION	QUANTITY
1	M5 Bolt	1
2	Plunger Rod	1
3	Cap Nut	1
4	O-Ring (Upper)	1
5	O-Ring (Lower)	1
6	Plastic Cap	1
7	Plastic Washer	2
8	Taper Spring	1
9	Steel Washer	1
10	Paper Washer	1
11	O-Ring	1
12	Plunger	1
13	Nyloc Nut (1/4")	1
14	Head	1

REF NO.	PARTS DESCRIPTION	QUANTITY
15	Barrel	1
16	Rivet	1
17	Steel Washer	1
18	Steel Washer	1
19	Paper Washer	1
20	Bung Nut	1
21	Rivet	1
22	U-Clip	1
23	Grip	1
24	Lever Handle	1
25	Rivet	1
26	Nyloc Nut (M5)	2
27	Telescopic Suction Tube	1
28	Bend Pipe	1

TROUBLESHOOTING

PROBLEM	POSSIBLE CAUSE	CORRECTIVE ACTION
Leakage of media from the pump	Damaged seal (O-ring) due to use with media not suitable for use with pump	Replace seal (O-ring) with genuine replacement seal (O-ring) from manufacturer and use only recommended media with the pump.
Pump does not dispense fluid or does not prime	Pump not able to create adequate suction	Prime the pump. Refer "Priming" section
	Pump is drawing in air, instead of fluid	Tighten all connections of suction tube & of the suction tube with pump inlet. Inspect pump cover(s) and seals for leaks. Tighten fasteners or replace gaskets / seals. Use thread sealant
	Suction tube inlet is clogged	Remove suction tube & clean the tube inlet
Handle difficult or impossible to move	Compression nut is too tight	Loosen the compression nut
	Pump has not been used for a long time	Remove pump cover and inspect for deposits on components and corroded parts. Clean or replace parts. Flush pump with the media being used if pump is not in use over long periods of time.
	Damaged or worn pump parts	Remove pump cover & inspect internal parts. Replace worn or damaged parts

DISPOSAL

The components or the used products must be given to companies that specialize in the disposal and recycling of industrial waste.